

尺寸图 Dimensional drawing

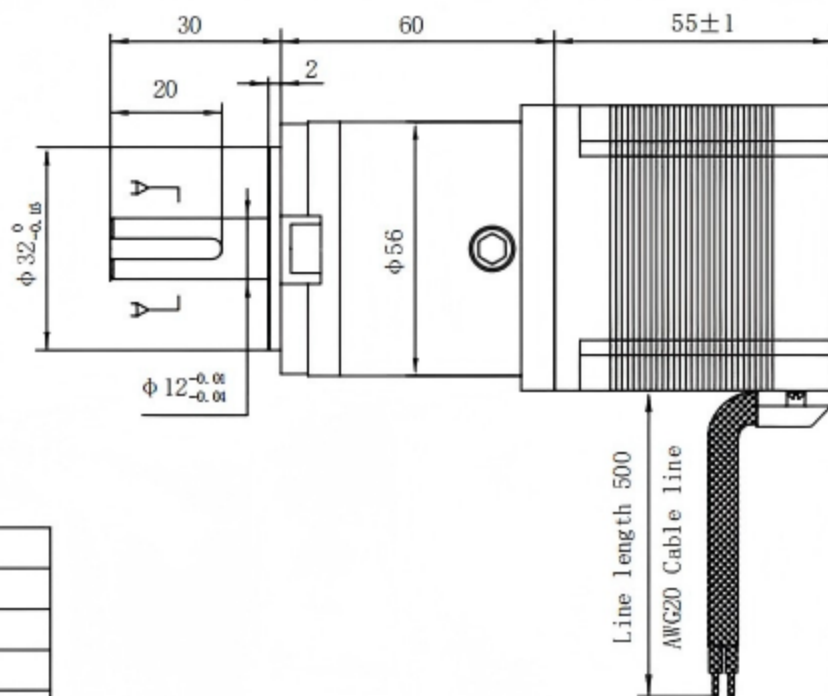

绕线图 Wiring Diagram

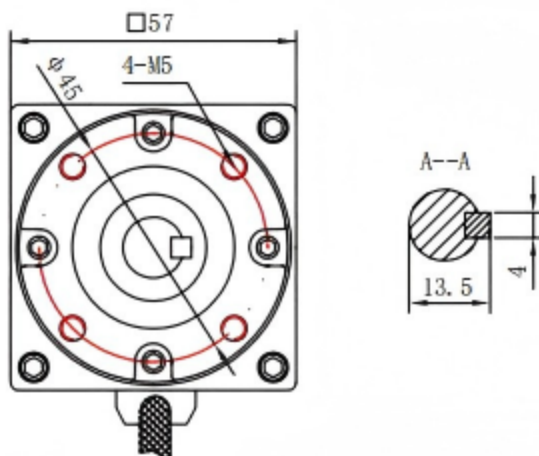
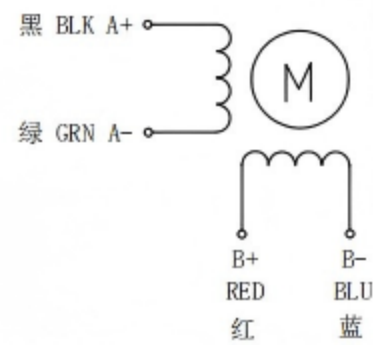

Excitation sequence and direction of clockwise

STEP	A+	B+	A-	B-
1	+	+	-	-
2	-	+	+	-
3	-	-	+	+
4	+	-	-	+

CW ← → CCW

seen from the mounting surface It is clockwise

1.步距角 Step angle	1.8° ±5%
2.相数 Number of phase	2
3.相电压 Phase voltage	2.52 VDC
4.相电流 Phase current	2.8 Amp
5.相电阻 Phase resistance	0.9 Ω ±10% (At 20° C)
6.相电感 Phase inductance	2.5 mH±20%
7.静力矩 Static moment	1.26 N.m
8.绝缘等级 Insulation class	Class B
9.绝缘电阻 Insulation resistance	100MΩ min. (500V DC)
10.环境温度 Ambient temperature	-20° ~ +50°
11.环境湿度 Ambient hum	15% to 95%
12.电机重量 Motor weight	Approx 1.45 Kg
13.使用电压 Use voltage	VDC:20-48V VAC24-36V
14.推荐驱动器 Recommended drive	2D8060MC

减速机级数 Reducer series	Grade 1	Grade 2	Grade 3
减速比 Exact reduction ratio	3.6 4.25	12.96 15.3 18.06	46.66 55.08 65.03 76.77
减速机长度 (L-mm)	48	60	72
额定负载 Rated load	15	30	40
最大负载 Maximum load	25	40	50
效率 Efficiency %	90	80	70
噪音 (DB) Noise	≤60	≤60	≤60
减速机重量 Reducer weight (KG)	0.55	0.75	0.95

工艺 Technology		单位 Unit	mm	DRAINING	57DL56-284A-PG15
设计 Design					
审核 Check				Shenzhen Sunshine Sea Technology Co.,Ltd	
批准 Approved	Betty Y	比列 Scale	1: 1		