

尺寸图 Dimensional drawing

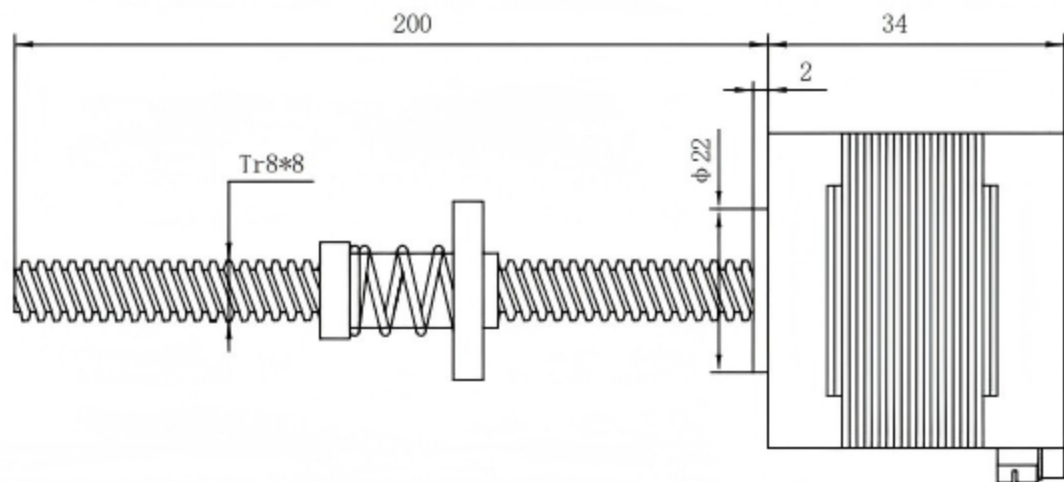

绕线图 Wiring Diagram

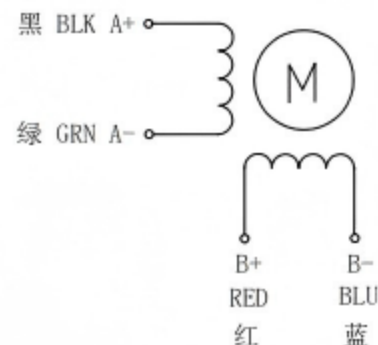

1.步距角 Step angle	1.8° ±5%
2.相数 Number of phase	2
3.相电压 Phase voltage	12 VDC
4.相电流 Phase current	0.4 Amp
5.相电阻 Phase resistance	30 Ω ±10% (At 20° C)
6.相电感 Phase inductance	37 mH±20%
7.静力矩 Static moment	0.28 N.m
8.绝缘等级 Insulation class	Class B
9.绝缘电阻 Insulation resistance	100MΩ min. (500V DC)
10.环境温度 Ambient temperature	-20° ~+50°
11.环境湿度 Ambient hum	15% to 95%
12.电机重量 Motor weight	Approx 0.2 Kg
13.使用电压 Use voltage	VDC:12-36V
14.推荐驱动器 Recommended drive	OK2D4020A

螺母尺寸图 POM材质消除

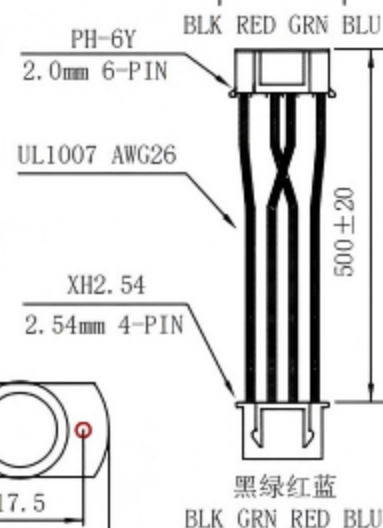
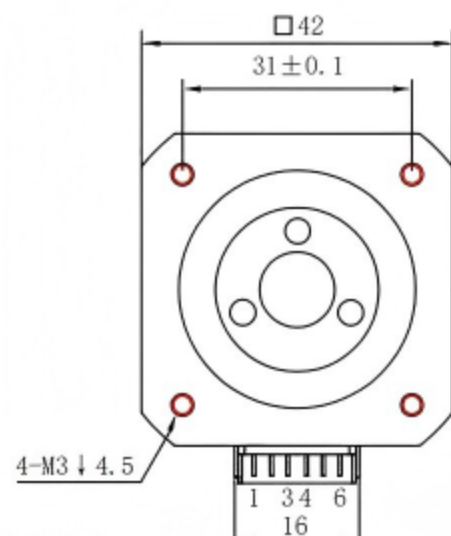
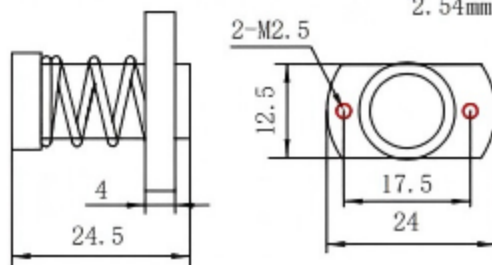

Excitation sequence and direction of clockwise

STEP	A+	B+	A-	B-
1	+	+	-	-
2	-	+	+	-
3	-	-	+	+
4	+	-	-	+

seen from the mounting surface It is clockwise

工艺 Technology

单位 Unit

mm

DRAWING

42STH34-044E-200G-C1

设计 Design

审核 Check

批准 Approved

Betty Y

比列 Scale

1: 1

Shenzhen Sunshine Sea Technology Co.,Ltd