

尺寸图 Dimensional drawing

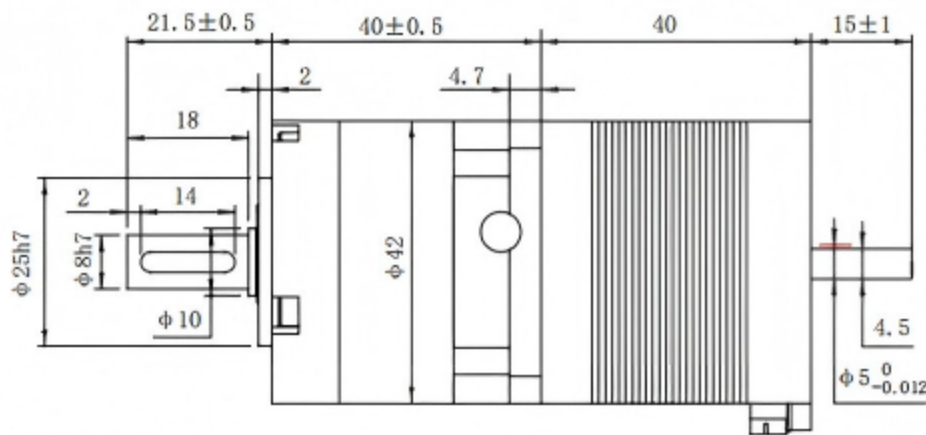

绕线图 Wiring Diagram

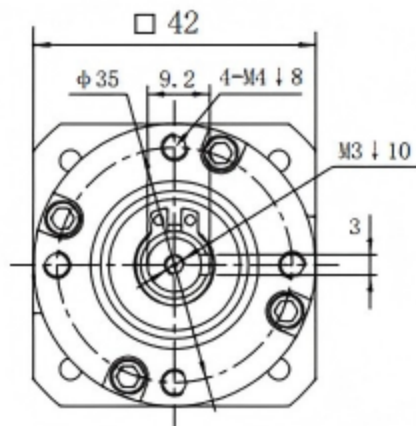
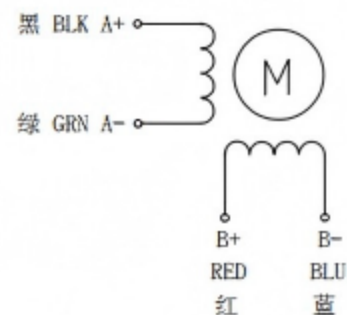

1.步距角 Step angle	0.9° ±5%
2.相数 Number of phase	2
3.相电压 Phase voltage	3.27 VDC
4.相电流 Phase current	1.5 Amp
5.相电阻 Phase resistance	1.6 Ω ±10% (At 20° C)
6.相电感 Phase inductance	4.0 mH ±20%
7.静力矩 Static moment	0.35 N.m
8.绝缘等级 Insulation class	Class B
9.绝缘电阻 Insulation resistance	100MΩ min. (500V DC)
10.环境温度 Ambient temperature	-20° ~+50°
11.环境湿度 Ambient hum	15% to 95%
12.电机重量 Motor weight	Approx 0.3 Kg
13.使用电压 Use voltage	VDC:12-36V
14.推荐驱动器 Recommended drive	OK2D4020A

规格型号 (Model)	速比	额定输出 扭矩TN (Nm)	噪音 (DB) Noise	效率 Efficiency	回差 Arcmin (arcmin)	长度 (L-mm)
OKD42HPR3G	3:1	8	<55	96%	<15	40
OKD42HPR4G	4:1	9	<55	96%	<15	40
OKD42HPR5G	5:1	5	<55	96%	<15	40
OKD42HPR7G	7:1	5	<55	96%	<15	40
OKD42HPR10G	10:1	12	<55	94%	<20	51
OKD42HPR15G	15:1	12	<55	94%	<20	51
OKD42HPR16G	16:1	10	<55	94%	<20	51
OKD42HPR20G	20:1	10	<55	94%	<20	51
OKD42HPR25G	25:1	10	<55	94%	<20	51
OKD42HPR28G	28:1	10	<55	94%	<20	51
OKD42HPR30G	30:1	10	<55	94%	<20	51
OKD42HPR35G	35:1	10	<55	94%	<20	51
OKD42HPR40G	40:1	10	<55	94%	<20	51
OKD42HPR50G	50:1	10	<55	94%	<20	51
OKD42HPR70G	70:1	10	<55	94%	<20	51
OKD42HPR100G	100:1	5	<55	94%	<20	51

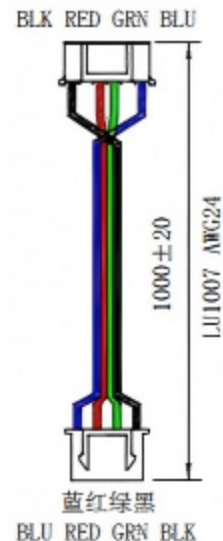

工艺 Technology		单位 Unit	mm
设计 Design			
审核 Check			
批准 Approved	Betty Y	比例 Scale	1:1

DRAWING

42HC40-154MB-HPR10

Shenzhen Sunshine Sea Technology Co.,Ltd