

尺寸图 Dimensional drawing

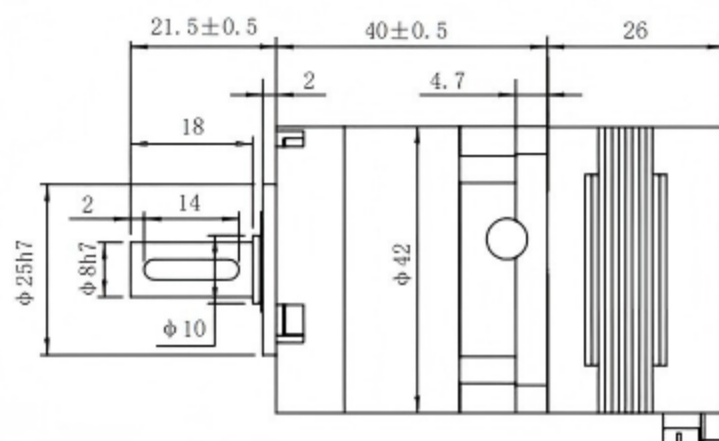

绕线图 Wiring Diagram

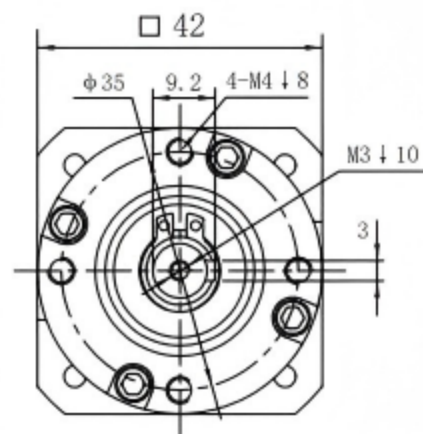
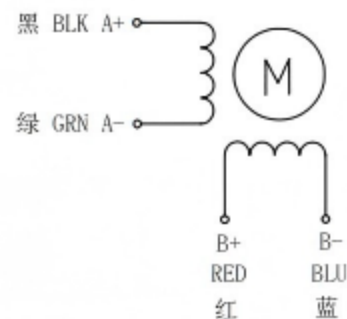

Excitation sequence and direction of clockwise

STEP	A+	B+	A-	B-
1	+	+	-	-
2	-	+	+	-
3	-	-	+	+
4	+	-	-	+

CW (Clockwise) and CCW (Counter-clockwise) directions are indicated by arrows.

seen from the mounting surface It is clockwise

1.步距角 Step angle	0.9° ±5%
2.相数 Number of phase	2
3.相电压 Phase voltage	3.36 VDC
4.相电流 Phase current	1.4 Amp
5.相电阻 Phase resistance	2.4 Ω ±10% (At 20° C)
6.相电感 Phase inductance	5.5 mH ±20%
7.静力矩 Static moment	0.18 N.m
8.绝缘等级 Insulation class	Class B
9.绝缘电阻 Insulation resistance	100MΩ min. (500V DC)
10.环境温度 Ambient temperature	-20° ~+50°
11.环境湿度 Ambient hum	15% to 95%
12.电机重量 Motor weight	Approx 0.24Kg
13.使用电压 Use voltage	VDC:12-36V
14.推荐驱动器 Recommended drive	OK2D4020A

减速机级数 Reducer series	Level 1				Level 2							
减速比 Exact reduction ratio	3	4	5	10	12	16	20	25	35	40	50	70
额定负载 Rated load (N.m)	8	9	9	5	10	10	10	10	10	10	10	10
减速机长度 (L-mm)	40				51							
效率 Efficiency %	96				94							
回差 Arcmin (arcmin)	≤15				≤20							
噪音 (DB) Noise	≤55				≤55							
减速机重量 Reducer weight	0.25				0.35							

工艺 Technology	单位 Unit	mm
设计 Design		
审核 Check		
批准 Approved	Betty Y	比例 Scale 1: 1

DRAWING

42HC26-144MA-PE10G

Shenzhen Sunshine Sea Technology Co., Ltd