

SSS-Motors

The output shaft size can be customized

尺寸图 Dimensional drawing

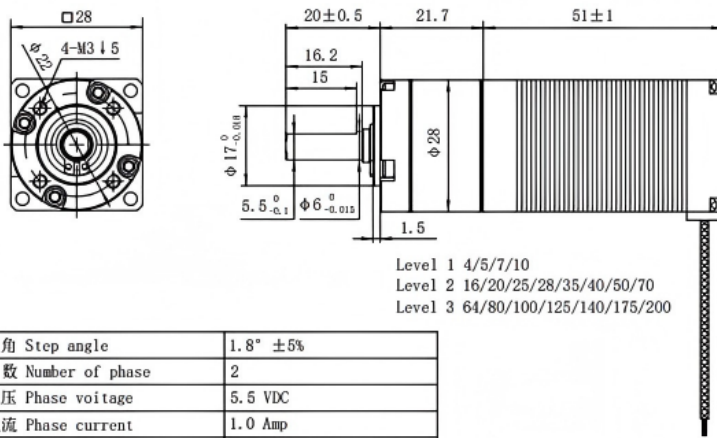

绕线图 Wiring Diagram

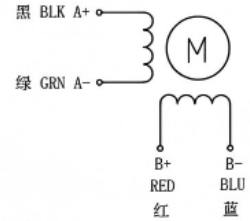

Excitation sequence and direction of clockwise

STEP	A+	B+	A-	B-
1	+	+	-	-
2	-	+	+	-
3	-	-	+	+
4	+	-	-	+

seen from the mounting surface It is clockwise

1.步距角 Step angle	1.8° ±5%
2.相数 Number of phase	2
3.相电压 Phase voltage	5.5 VDC
4.相电流 Phase current	1.0 Amp
5.相电阻 Phase resistance	4.9 Ω ±10% (At 20° C)
6.相电感 Phase inductance	5.2 mH ±20%
7.静力矩 Static moment	1200 g.cm
8.绝缘等级 Insulation class	Class B
9.绝缘电阻 Insulation resistance	100MΩ min. (500V DC)
10.环境温度 Ambient temperature	-20° ~+50°
11.环境湿度 Ambient hum	15% to 95%
12.电机重量 Motor weight	Approx 0.2Kg
13.使用电压 Use voltage	VDC:12-24V
14.推荐驱动器 Recommended drive	OK2D4020A

The output torque refers to the maximum torque that the gearbox can bear, and exceeding it will cause gear damage

Reduction Ratio	4	5	7	10	16	20	25	28	35	40	50	70	100
Exact Reduction Ratio	1	1	1	1	2	2	2	2	2	2	2	2	3
Gear Box Length(L)	21.7	21.7	21.7	21.7	31.2	31.2	31.2	31.2	31.2	31.2	31.2	31.2	38.7
效率 Efficiency %	90	90	90	90	81	81	81	81	81	81	81	81	73
噪音 (DB) Noise	≤55	≤55	≤55	≤55	≤55	≤55	≤55	≤55	≤55	≤55	≤55	≤55	≤55
回差 Arcmin	≤10	≤10	≤10	≤10	≤15	≤15	≤15	≤15	≤15	≤15	≤15	≤15	≤25
Output Torque (N.m)	2	2	2	1	4	4	4	4	4	4	3	3	6

工艺 Technology		单位 Unit	mm		DRAWING	28FD51-104A-HPR5G-F1
设计 Design						
审核 Chck						
批准 Approved	Betty Y	比列 Scale	1: 1	Shenzhen Sunshine Sea Technology Co.,Ltd		